

# Loman



	Seat - Assise	Backrests - Dossiers	Structure - Structure		
<b>Upholstering</b> <i>Revetement</i> (10)	Removable <i>Déhoussable</i>				
	Not removable <i>Non déhoussable</i>	—	—		
<b>Padding</b> <i>Rembourrages</i> (2-4-5-6-7-8)	+ D.30kg/m³	 Mixed feather	 Tecnoform	 ETHICALLY SOFT MADE optional	

## TECHNICAL INFORMATION

### Structure: 1

Supporting structure in pinewood of various thicknesses. Remaining parts in class E1 particleboard panels, hardboard or cellulose wood-based panels details.

### Springing: 1-3

The back is made of hard or cellulose wooden fibre panels. The seat is supported by propylene and latex elastic belts.

### Note:

Metal back support (9) covered with fabric, simil leather or removable leather. Laquered steel bookcase, top or small table.

## INFORMATIONS TECHNIQUES

### Structure: 1

Structure porteuse en bois de pin de différentes épaisseurs. Autres parties en panneaux de particules de bois en classe E1, détails en panneaux de fibre de bois dure ou cellulose.

### Suspension: 1-3

Dossier en panneaux de fibre de bois dure ou cellulose. Assise avec sangles élastiques de fibre propylénique et latex.

### Note:

Supports du dossier (9) en métal revetues en tissu, similcuir ou cuir déhoussable. Bibliothèque, plan ou table en acier verni.

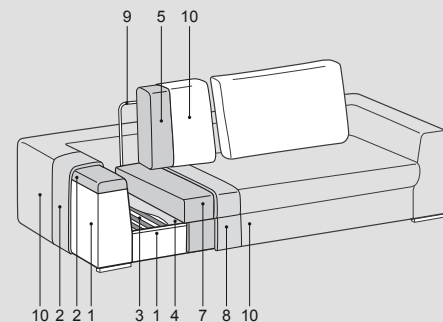
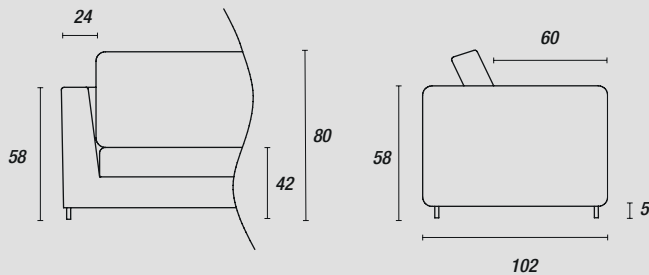

### Feet - Pieds::

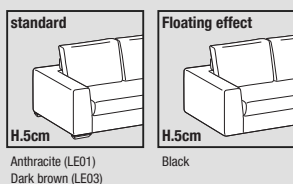



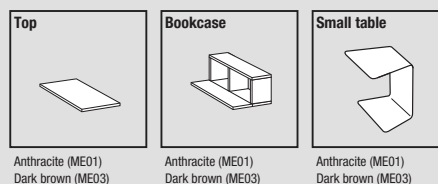



### Accessories - Accessoires:

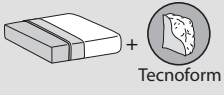

# Loman soft

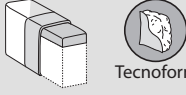

	Seat - Assise	Backrests - Dossiers	Structure - Structure	
<b>Upholstering</b> <i>Revetement</i> (10)	Removable <i>Déhoussable</i>			
	Not removable <i>Non déhoussable</i>	—	—	—
<b>Padding</b> <i>Rembourrages</i> (2-4-5-6-7-8)	 D.30kg/m³	 Mixed feather	 Tecnoform	 optional

## TECHNICAL INFORMATION

### Structure: 1

Supporting structure in pinewood of various thicknesses. Remaining parts in class E1 particleboard panels, hardboard or cellulose wood-based panels details.

### Springing: 1-3

The back is made of hard or cellulose wooden fibre panels.  
The seat is supported by propylene and latex elastic belts.

### Note:

Metal back support (9) covered with fabric, simil leather or removable leather.  
Laquered steel bookcase, top or small table.

## INFORMATIONS TECHNIQUES

### Structure: 1

Structure porteuse en bois de pin de différentes épaisseurs. Autres parties en panneaux de particules de bois en classe E1, détails en panneaux de fibre de bois dure ou cellulose.

### Suspension: 1-3

Dossier en panneaux de fibre de bois dure ou cellulose.  
Assise avec sangles élastiques de fibre propylénique et latex.

### Note:

Supports du dossier (9) en métal revêtues en tissu, similcuir ou cuir déhoussable.  
Bibliothèque, plan ou table en acier verni.

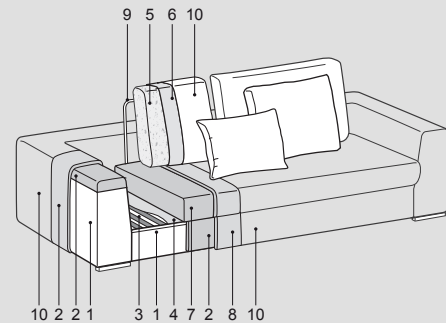
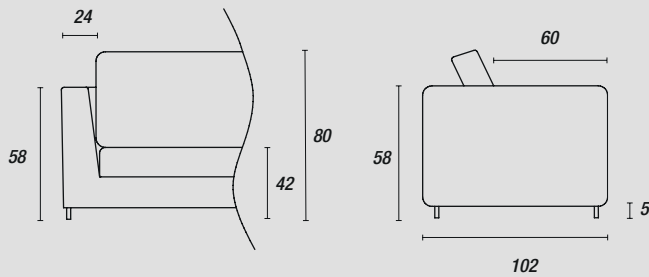

### Feet - Pieds::

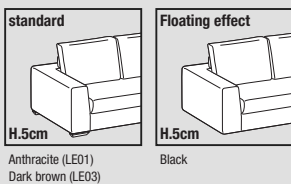

### Accessories - Accessoires:

