

# Dalton



	Seduta - Seat	Schienali - Backrests	Struttura - Structure	
<b>Rivestimento Upholstering (10)</b>	Sfoderabile Removable Non sfoderabile Not removable	Sfoderabile Removable Non sfoderabile Not removable	Sfoderabile Removable Non sfoderabile Not removable	
<b>Imbottiture Padding (2-4-5-6-7-8)</b>	D.35/40kg/m³	D.18kg/m³	Pol.espanso Tecnoform	<b>ECOSY</b> ETHICALLY SOFT MADE Optional

## INFORMAZIONI TECNICHE

### Struttura: 1-3

Struttura portante in pannelli di legno multistrato in classe E1 e masselli portanti in abete di vari spessori, tamponamenti in pannelli di particelle di legno in classe E1.

### Molleggio: 1-11

Schienale in nastri elastici di fibra propilenica e lattice. Seduta in pannelli di multistrato in classe E1.

### Note:

Con i piedi UP l'intero divano o composizione possono essere alzati di 5cm rispetto alle dimensioni riportate.

## TECHNICAL INFORMATION

### Structure: 1-3

Supporting structure in class E1 plywood panels and supporting solid fir wood of differing thicknesses, buffers in class E1 particleboard panels.

### Springing: 1-11

The back is supported by propylene and latex elastic belts. Seat in class E1 plywood panels.

### Note:

With UP feet the whole sofa or composition can be raised 5 cm compared to the dimensions shown.

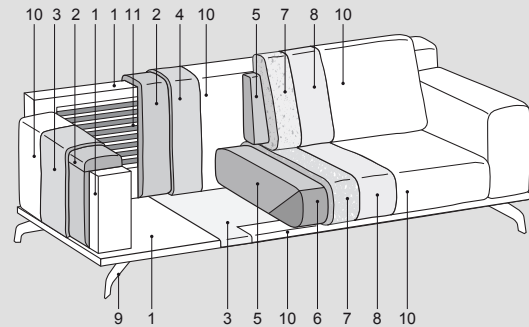
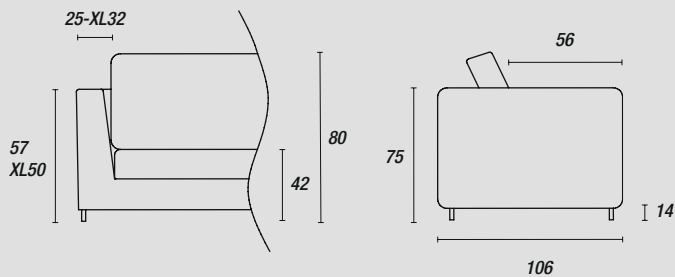



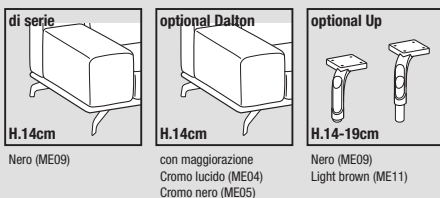



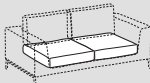
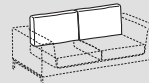
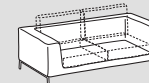

### Piedini - Feet:



# Dalton soft



	 Seduta - Seat	 Schienali - Backrests	 Struttura - Structure	
<b>Rivestimento Upholstering (10)</b>	Sfoderabile Removable 	Sfoderabile Removable 	Sfoderabile Removable 	
	Non sfoderabile Not removable -	Non sfoderabile Not removable -	Non sfoderabile Not removable -	
<b>Imbottiture Padding (2-4-5-6-7-8)</b>	 D.35/40kg/m³	 Misto piuma	 Pol.espanso Tecnoform	 Optional

## INFORMAZIONI TECNICHE

### Struttura: 1-3

Struttura portante in pannelli di legno multistrato in classe E1 e masselli portanti in abete di vari spessori, tamponamenti in pannelli di particelle di legno in classe E1.

### Molleggio: 1-11

Schienale in nastri elastici di fibra propilenica e lattice.  
Seduta in pannelli di multistrato in classe E1.

### Note:

Con i piedi UP l'intero divano o composizione possono essere alzati di 5cm rispetto alle dimensioni riportate.

## TECHNICAL INFORMATION

### Structure: 1-3

Supporting structure in class E1 plywood panels and supporting solid fir wood of differing thicknesses, buffers in class E1 particleboard panels.

### Springing: 1-11



The back is supported by propylene and latex elastic belts.  
Seat in class E1 plywood panels.

### Note:

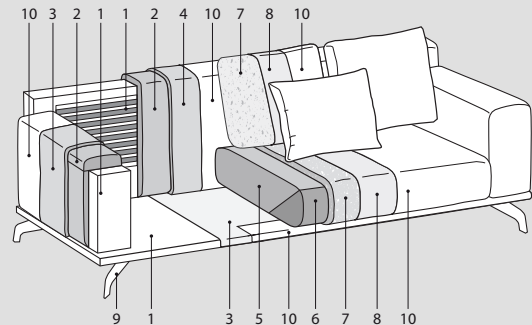
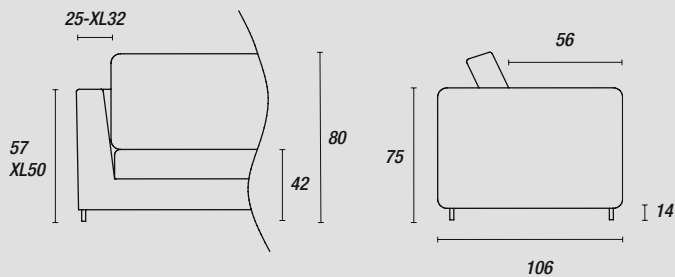
With UP feet the whole sofa or composition can be raised 5 cm compared to the dimensions shown.

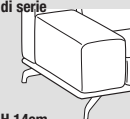
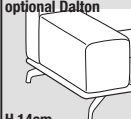

### Piedini - Feet:

 di serie H.14cm Nero (ME09)	 optional Dalton H.14cm con maggiorazione Cromo lucido (ME04) Cromo nero (ME05)	 optional Up H.14-19cm Nero (ME09) Light brown (ME11)
--	---	--