

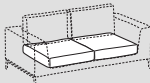

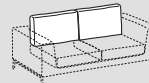

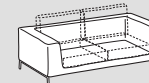

Flick - Flack

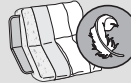
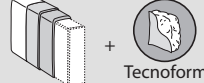

| |  Seduta - Seat |  Schienali - Backrests |  Struttura - Structure | |
|--------------------------------------|---|---|---|---|
| Rivestimento Upholstering (9) | Sfoderabile Removable  | Sfoderabile Removable  | Sfoderabile Removable  | |
| | Non sfoderabile Not removable - | Non sfoderabile Not removable - | Non sfoderabile Not removable - | |
| Imbottiture Padding (5-6-7-8) |  D.35kg/m ³ |  D.30kg/m ³ |  Pol.espanso |  Optional |

INFORMAZIONI TECNICHE

Struttura: 1-2-3

Masselli portanti in abete di vari spessori. Fianchi di tamponamento in pannelli di particelle di legno in classe E1, particolari in pannelli di fibra di legno dura o cellulosa.

Molleggio: 4-11

Schienali con nastri elastici di fibra propilenica e lattice. Seduta in molle greche in metallo.

Note:

Gli schienali hanno al loro interno un meccanismo frizionato (11) che permette la funzione di sollevamento / abbassamento dello schienale nella posizione desiderata.

TECHNICAL INFORMATION

Structure: 1-2-3

Supporting structure in pinewood of various thicknesses. Remaining parts in class E1 particleboard panels, hardboard or cellulose wood-based panels details.

Springing: 4-11

The back is supported by propylene and latex elastic belts. The seat is supported by Nosag-springs.

Note:

The backs (11) have a metal lift/lower mechanism to position the backrest as desired.

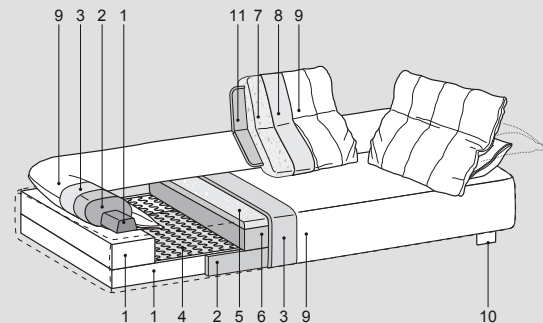
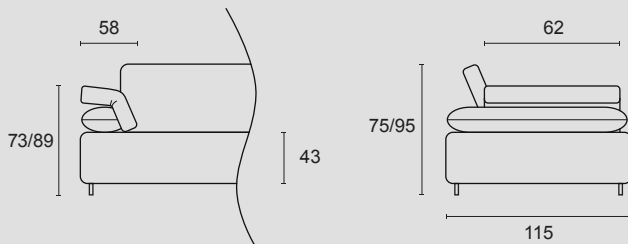

Piedini - Feet:

di serie



H.6cm

Eucalipto (LE05)