

# Monolith



	Seduta - Seat	Schienali - Backrests	Struttura - Structure	
<b>Rivestimento Upholstering (6)</b>	Sfoderabile Removable	Sfoderabile Removable	Sfoderabile Removable	
	Artificial Leather	Artificial Leather	Artificial Leather	
	Non sfoderabile Not removable	Non sfoderabile Not removable	Non sfoderabile Not removable	
<b>Imbottiture Padding (2-3-4-7-8)</b>	Tecnoform D.35kg/m³	Tecnoform D.25kg/m³	Pol.espanso Tecnoform	

## INFORMAZIONI TECNICHE

### Struttura: 1

Masselli portanti in abete di vari spessori. Fianchi di tamponamento in pannelli di particelle di legno in classe E1, particolari in pannelli di fibra di legno dura o cellulosa.

### Molle: 9

Schienale in nastri elastici di fibra propilenica e lattice.  
Seduta in nastri elastici di fibra propilenica e lattice.

## TECHNICAL INFORMATION

### Structure: 1

Supporting structure in pinewood of various thicknesses. Remaining parts in class E1 particleboard panels, hardboard or cellulose wood-based panels details.

### Springing: 9

The back is supported by propylene and latex elastic belts.  
The seat is supported by propylene and latex elastic belts.

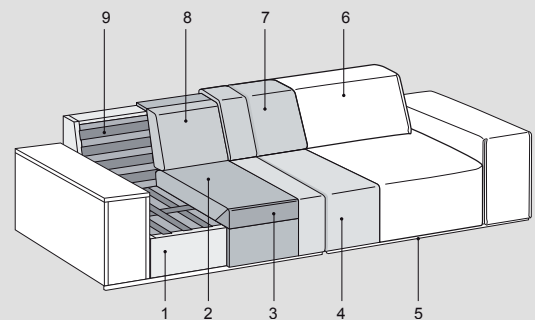
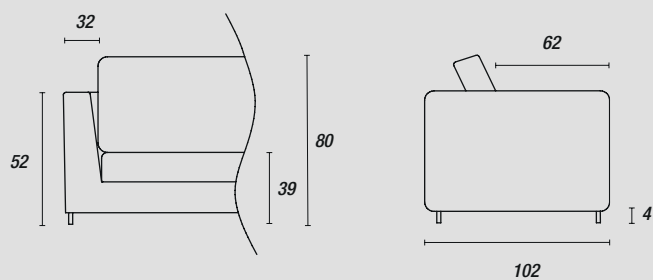

Piedini - Feet:

di serie Basamento

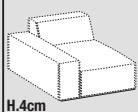

Eucalipto (LE05)