

Epoque fashion



	Seduta - Seat	Schienali - Backrests	Struttura - Structure	
Rivestimento Upholstering (12)	Sfoderabile / Removable Non sfoderabile / Not removable	Sfoderabile / Removable Non sfoderabile / Not removable	Sfoderabile / Removable Non sfoderabile / Not removable	
Imbottiture Padding (2-4-5-6-7-8-9)	D.35kg/m³	Misto piuma	Pol.espanso + Tecnoform	 Optional

INFORMAZIONI TECNICHE

Struttura: 1

Struttura portante in pannelli di multistrato di legno classe E1 e masselli di legno di abete o faggio, sostenuta da supporto in metallo, il tutto avvolto da lastre di poliuretano espanso a densità differenziate.

Molleggio: 1-3

Schienale in pannelli di fibra di legno dura o cellulosa. Molleggio della seduta in nastri elastici di fibra propilenica e lattice.

Note:

Piedini in metallo (10) e profilo del bracciolo (11) disponibili nello stesso colore.

I divani possono essere agganciati ad elementi laterali a formare delle composizioni.

L'ordine di ogni composizione deve sempre essere corredato da un disegno in pianta.

TECHNICAL INFORMATION

Structure: 1

Supporting frame in class E1 plywood panels and solid spruce or beech wood, with metal support, all wrapped in expanded polyurethane sheets of different densities.

Springing: 1-3

The back is made of hard or cellulose wooden fibre panels. Seat spring with propylene fibre and latex elastic webbing.

Note:

Metal feet (10) and arm profile (11) available in the same color.

The sofas can be attached to side chairs to create different compositions. For orders of compositions a sketch is requested.

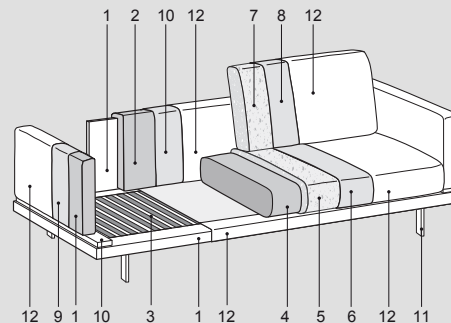
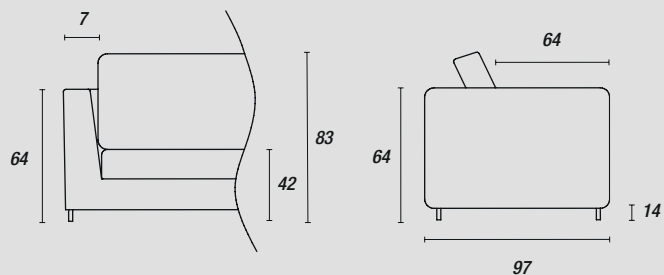

Piedini - Feet:

di serie

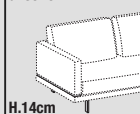







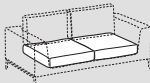
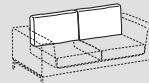
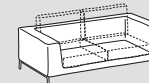

H.14cm

Nero (ME09)
Grigio Seta (LE10)

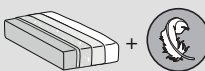
Epoque fashion mix

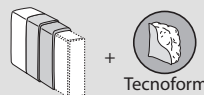

	 Seduta - Seat	 Schienali - Backrests	 Struttura - Structure	
Rivestimento Upholstering (12)	Sfoderabile Removable 	Sfoderabile Removable 	-	
	Non sfoderabile Not removable -	Non sfoderabile Not removable -	 Cat. Soft	
Imbottiture Padding (2-4-5-6-7-8-9)	 D.35kg/m³	 Misto piuma	 Pol.espanso + Tecnoform	 Optional

INFORMAZIONI TECNICHE

Struttura: 1

Struttura portante in pannelli di multistrato di legno classe E1 e masselli di legno di abete o faggio, sostenuta da supporto in metallo, il tutto avvolto da lastre di poliuretano espanso a densità differenziate.

Molleggio: 1-3

Schienale in pannelli di fibra di legno dura o cellulosa.
Molleggio della seduta in nastri elastici di fibra propilenica e lattice.

Note:

Scocca rivestita in pelle Cat. Soft; per articolo imbottito con parti in pelle di altre categorie, aggiungere la maggiorazione indicata.

Piedini in metallo (10) e profilo del bracciolo (11) disponibili nello stesso colore.

I divani possono essere agganciati ad elementi laterali a formare delle composizioni.

L'ordine di ogni composizione deve sempre essere corredato da un disegno in pianta.

TECHNICAL INFORMATION

Structure: 1

Supporting frame in class E1 plywood panels and solid spruce or beech wood, with metal support, all wrapped in expanded polyurethane sheets of different densities.

Springing: 1-3

The back is made of hard or cellulose wooden fibre panels.
Seat spring with propylene fibre and latex elastic webbing.

Note:

Base covered with Soft leather; for articles upholstered with leather parts from other categories, consider the indicated surcharge

Metal feet (10) and arm profile (11) available in the same color.

The sofas can be attached to side chairs to create different compositions.

For orders of compositions a sketch is requested.

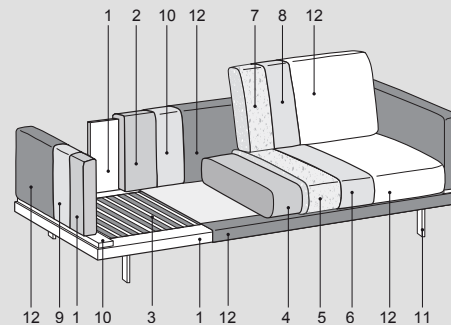
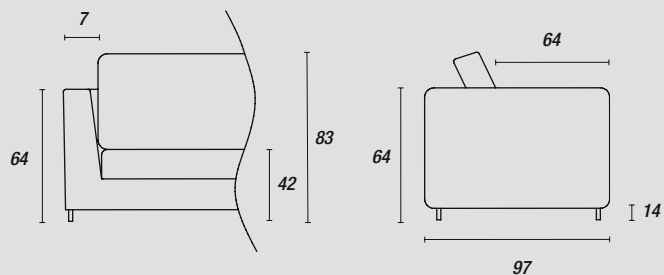

Piedini - Feet:

di serie

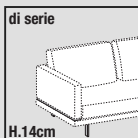

Nero (ME09)
Grigio Seta (LE10)