

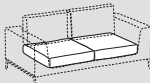

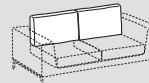

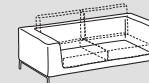











Dalton low



	 Seduta - Seat	 Schienali - Backrests	 Struttura - Structure	
Rivestimento Upholstering (10)	Sfoderabile Removable   	Sfoderabile Removable   	Sfoderabile Removable 	
	Non sfoderabile Not removable -	Non sfoderabile Not removable -	Non sfoderabile Not removable  	
Imbottiture Padding (2-4-5-6-7-8)	 +  D.35/40kg/m³	 +  D.18kg/m³	 +  Pol.espanso	 Optional

INFORMAZIONI TECNICHE

Struttura: 1-3

Struttura portante in pannelli di legno multistrato in classe E1 e masselli portanti in abete di vari spessori, tamponamenti in pannelli di particelle di legno in classe E1.
Struttura rivestita completamente in lastre di poliuretano espanso e Tecnoform.

Molleggio: 1-11

Schienale in nastri elastici di fibra propilenica e lattice meccanicamente pretensionati.
Seduta in pannelli di multistrato in classe E1.

Note:

Con i piedi UP l'intero divano o composizione possono essere alzati di 5cm rispetto alle dimensioni riportate.

TECHNICAL INFORMATION

Structure: 1-3

Supporting structure in class E1 plywood panels and supporting solid fir wood of differing thicknesses, buffers in class E1 particleboard panels.
Structure completely covered with foam and Tecnoform.

Springing: 1-11

Backrest with pre-tensioned elastic strips in propylene fibre and latex.
Seat in class E1 plywood panels.

Note:

With UP feet the whole sofa or composition can be raised 5 cm compared to the dimensions shown.

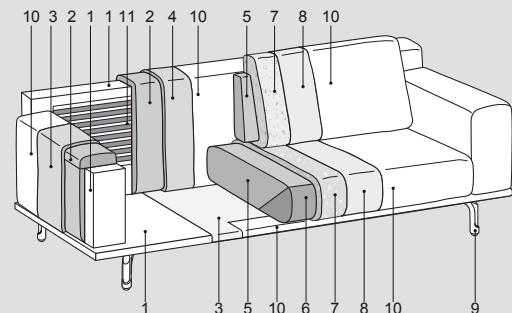
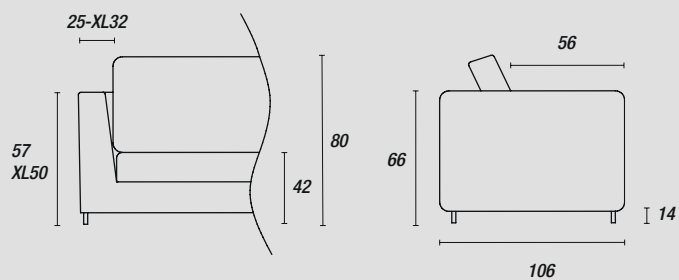

Piedini - Feet:

di serie UP



H.14-19cm
Nero (ME09)
Light brown (ME11)

optional Dalton

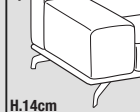

H.14cm
Nero (ME09)

optional Dalton

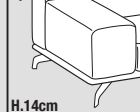

con maggiorazione
Cromo lucido (ME04)
Cromo nero (ME05)